

NOTES:

REVISION HISTORY				
REV	DATE	DESCRIPTION	ECO	BY
A	7/26/2013	RELEASED @ LA	14289	LA

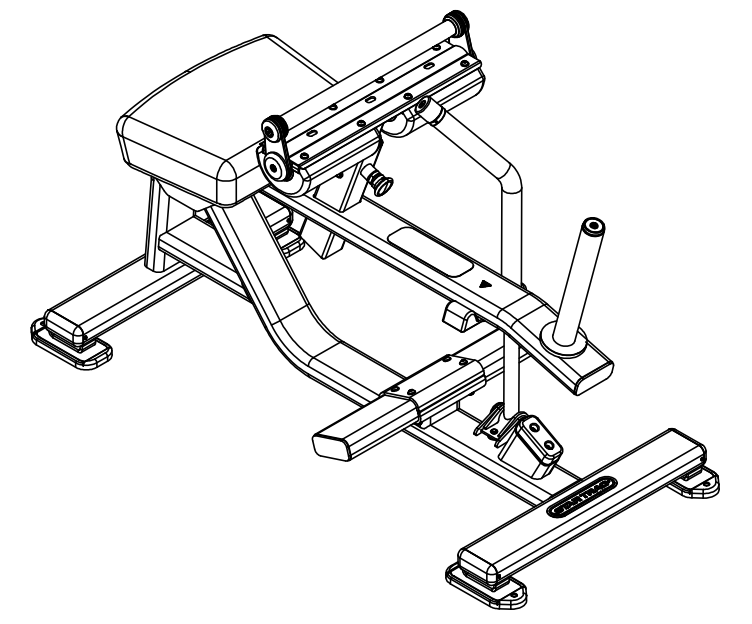
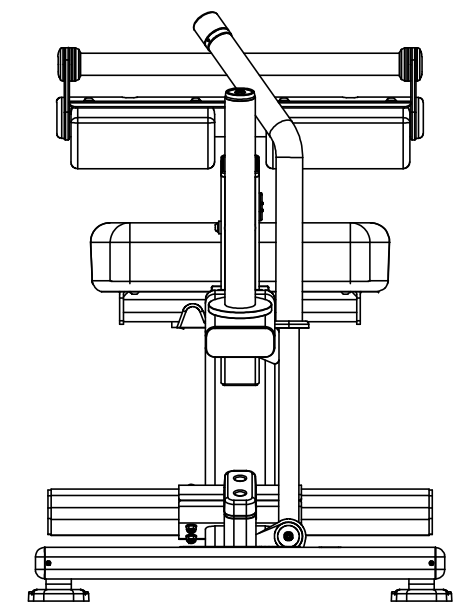
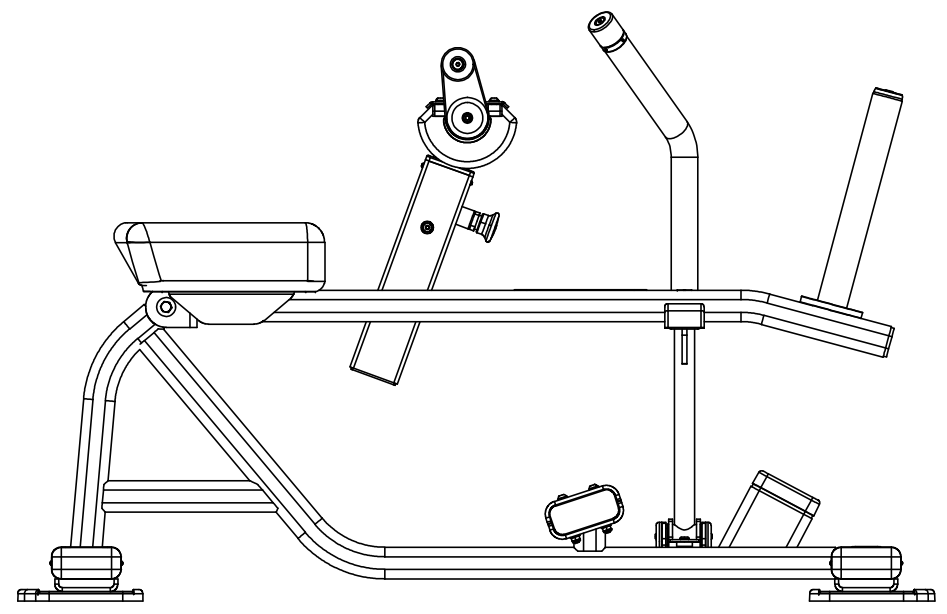
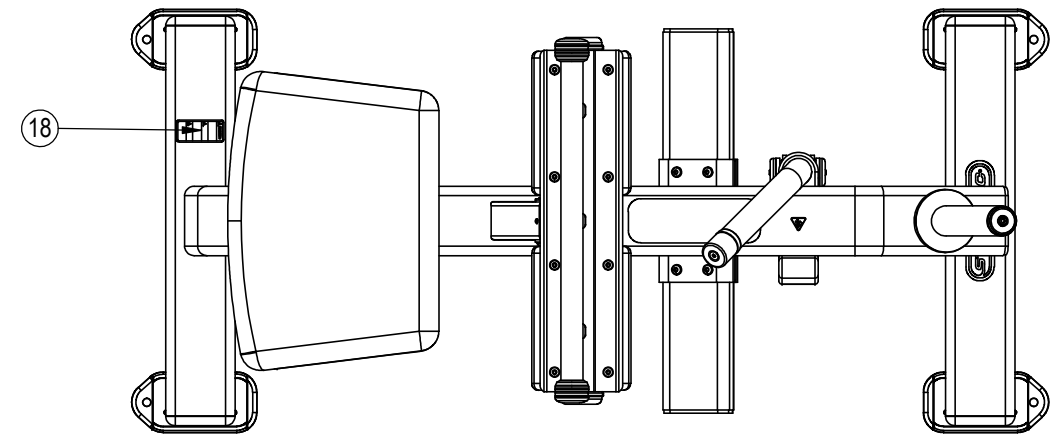

**DOCUMENT STATUS:**

NOTICE OF PROPRIETARY INFORMATION  
THIS DOCUMENT SHALL NOT BE REPRODUCED NOR SHALL THE INFORMATION CONTAINED HEREIN BE USED BY OR DISCLOSED TO OTHER EXCEPT AS EXPRESSLY AUTHORIZED BY CORE INDUSTRIES, INC., D.B.A. STAR TRAC.

CLASS OF WORK	UNLESS OTHERWISE SPECIFIED DIMS ARE IN mm. TOLERANCES FOR MEASURE OF LENGTH ARE:							ANGLES = ±2°
	0.5 to 3	> 3 to 6	> 6 to 30	> 30 to 120	> 120 to 400	> 400 to 1000	> 1000 to 2000	
FINE	±0.05	±0.05	±0.1	±0.15	±0.2	±0.3	±0.5	----
MEDIUM <b>X</b>	±0.1	±0.1	±0.2	±0.3	±0.5	±0.8	±1.2	±2
COARSE	±0.2	±0.3	±0.5	±0.8	±1.2	±2	±3	±4
VERY COARSE	----	±0.5	±1	±1.5	±2.5	±4	±6	±8

<b>MATERIAL</b> SEE BOM	<b>THIRD ANGLE PROJECTION</b> 	
<b>FINISH</b> N/A	DRAWN	DATE
<b>VENDOR: N/A</b>	INITIAL RLH	7/26/13
<b>P/N: N/A</b>	CHECKED	
	APPROVED	
	U.O.M.	MM

<b>CORE INDUSTRIES, INC. DBA</b> 		14410 Myford Road Irvine CA 92606	
STARTRAC PART NO	REV		
<b>IP-L1110-XXXXS</b>	<b>A</b>		
TITLE <b>LEVERAGE, TILT SEAT CALF</b>			
SCALE: 1:12	SHEET 1 OF 4	SHEET SIZE: B	

9		8		7		6		5		4		3		2		1	
	ITEM NO.	PART NUMBER	DESCRIPTION	QTY.		ITEM NO.	PART NUMBER	DESCRIPTION	QTY.								
J	1	730-0913	BUMPER,DIA 25MM	2		45	731-4213-00XX	ASSY, UPHOLSTERY, THIGH, LEG CURL	2								J
	2	731-0033	NUT, RIVET,M8 X 1.25	2		46	731-4221	RUBBER,STOP,TSC	1								
	3	731-0054	RING, BEAUTY, GRIP END	2		47	731-4222	TPE,WEIGHT LOCK, WEAR PAD	1								
	4	731-0055	CAP, OUTSIDE, GRIP, Ø32MM	2		48	731-4223-XX	WELDMENT,WEIGHT LOCK,TSC	1								
I	5	731-0137	BEARING,52 OD,25 ID,X 15MM	2		49	731-4224	BUSHING,26MM ID	2								
	6	731-0209	CAP, END, 110 X 50	4		50	731-4225	SHAFT,PIVOT,TSC	1								
	7	731-0225	SCREW,M3.5 X 9.5,SELF TAPPING	12		51	731-4227	BAR,SHAFT,MAIN,TSC	1								
	8	731-0235	SCREW,M8 X 1.25,75mm,BHC,HK	4		52	731-4228	RUBBER,WASHER,TSC	1								
	9	731-0290	CAP, GRIP, CURL	2		53	731-4229	RUBBER,GRIP,TSC	1								
H	10	731-0355	WASHER,PLAIN,M8,NARROW	23		54	731-4877	PLACARD,LEV,TILT SEAT CALF	1								
	11	731-0359	SCREW,M8 X 1.25,25mm,BHC,HK	15		55	731-4888	STICKER, NUMBER,ROM,L1110	1								
	12	731-0365	NUT,M8 X 1.25,NYLOC JAM	4													
	13	731-0374	SCREW,M6 X 1.0,16mm,BHC,HK	2													
	14	731-0390	SCREW,M8 X 1.25,25mm,SHC,HK	3													
G	15	731-0397	SCREW,M8 X 1.25,25mm,FHM,HK	3													
	16	731-0512	STICKER,WARNING,PINCH	2													
	17	731-0513	STICKER,STAR TRAC,DECO,45MMX191MM	1													
	18	731-0517	STICKER, WARNING, BOLT DOWN	1													
	19	731-0587	NUT,M4 X 0.7,LOCKING	2													
F	20	731-0637	RING,BEAUTY,ADJ,PAD	1													
	21	731-0638	SUPPORT,TUBE,ADJ,CHEST	1													
	22	731-0705	HAT, SPACER, 25 OD X 20 ID	2													
	23	731-1020	PLASTIC, SEAT BOTTOM , LEG MACHINE	1													
E	24	731-1226-00XX	ASSY, SEAT BOTTOM, SLP	1													
	25	731-1265	CAP,END,65MM,NO GROOVE	2													
	26	731-1357	CAP, BEARING 1 3/4 RND	2													
	27	731-1374	RUBBER,END CAP, WEIGHT HORN	1													
	28	731-1458-XX	BRACKET,BOTTOM,FOOT,WT STORAGE	1													
D	29	731-1785	SCREW,SET,M4X.7,4MM	2													
	30	731-2079	SCREW,M4 X .7,8MM,SHC,HK,NP	2													
	31	731-2080	BUMPER,ADJ,HYPER	1													
	32	731-2333	SCREW,M10X1.5,25MM,HHC,HE,CS,BZ	2													
	33	731-2346	WASHER,M10,FENDER,BZ	2													
C	34	731-2647	FOOT, LONG, LEVERAGE	4													
	35	731-2762	RUBBER BUMPER	1													
	36	731-3466	ASSY,LEV, BIG PIN	1													
	37	731-3775	END CAP,32MM	1													
	38	731-3776	TRIM RING,GRIP,32MM	1													
B	39	731-4161	COVER,WGT HOLDER,ILR	1													
	40	731-4195-XX	WELDMENT,WEIGHT ARM,TSC	1													
	41	731-4200-XX	WELDMENT, THIGH PAD SLIDER,TSC	1													
	42	731-4201	WELDMENT,GRIP.TSC	1													
	43	731-4204	WELDMENT,FOOT PAD,TSC	1													
A	44	731-4212-XX	WELDMENT,MAIN FRAME,TSC	1													

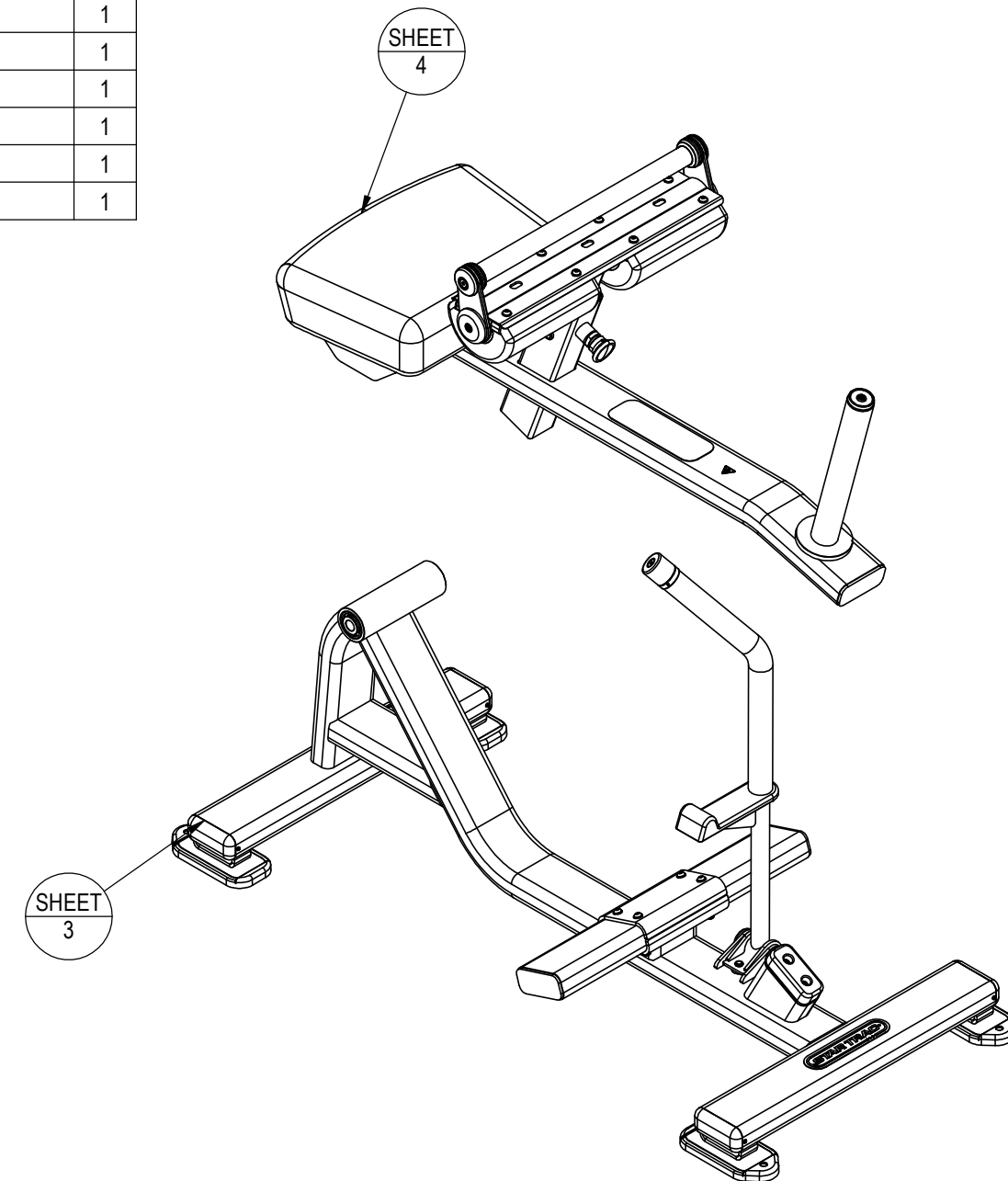



CORE INDUSTRIES, INC. DBA  
**STAR TRAC**  
 14410 Myford Road  
 Irvine CA 92606

STARTRAC PART NO  
**IP-L1110-XXXXS**  
 TITLE  
**LEVERAGE, TILT SEAT CALF**

REV  
**A**

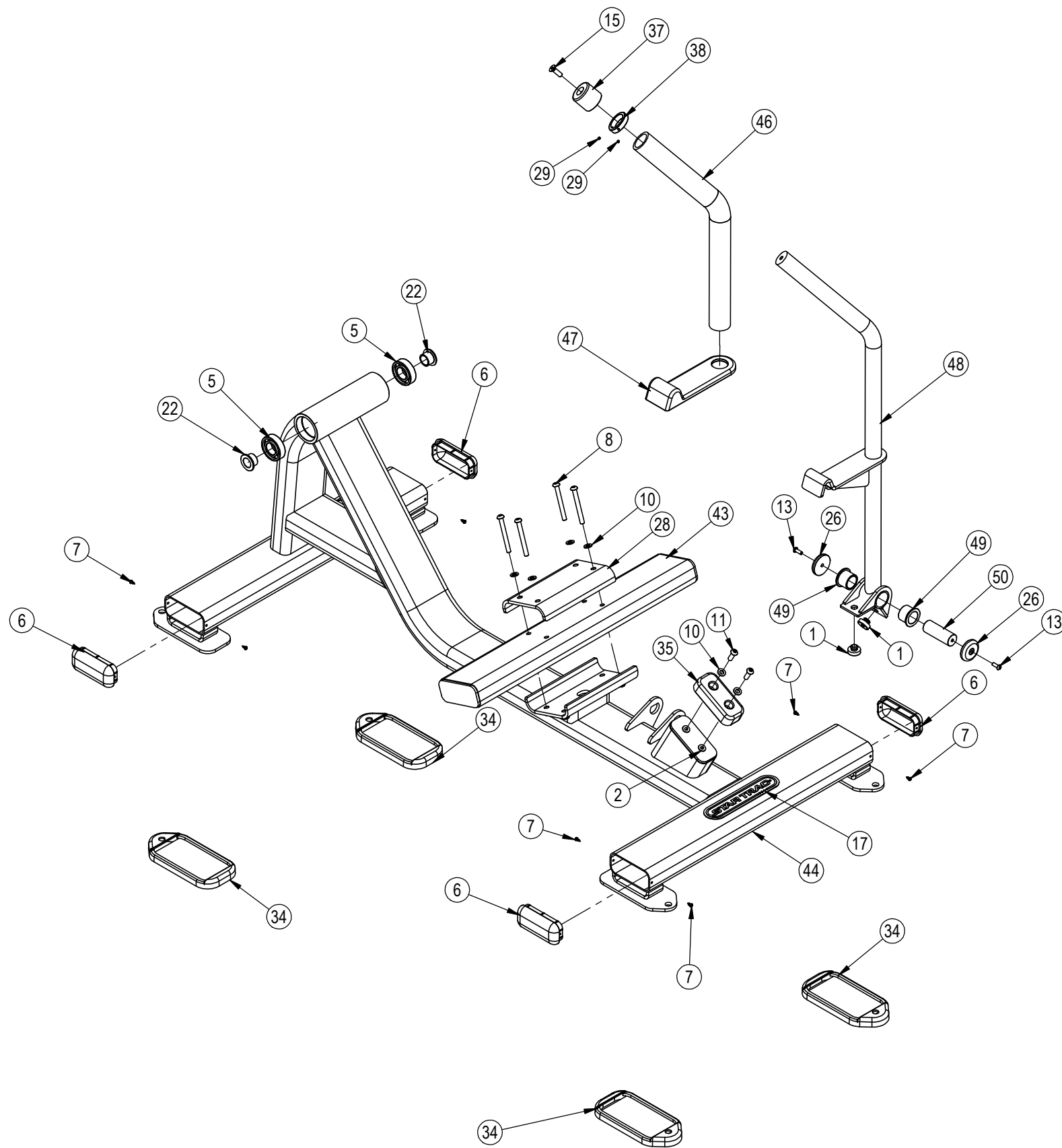
SCALE: 1:12 | SHEET 2 OF 4 | SHEET SIZE: B



CORE INDUSTRIES, INC. DBA		14410 Myford Road
		Irvine CA 92606
STARTRAC PART NO	REV	
<b>IP-L1110-XXXXS</b>	<b>A</b>	
TITLE		
<b>LEVERAGE, TILT SEAT CALF</b>		
SCALE: 1:10	SHEET 3 OF 4	SHEET SIZE: B

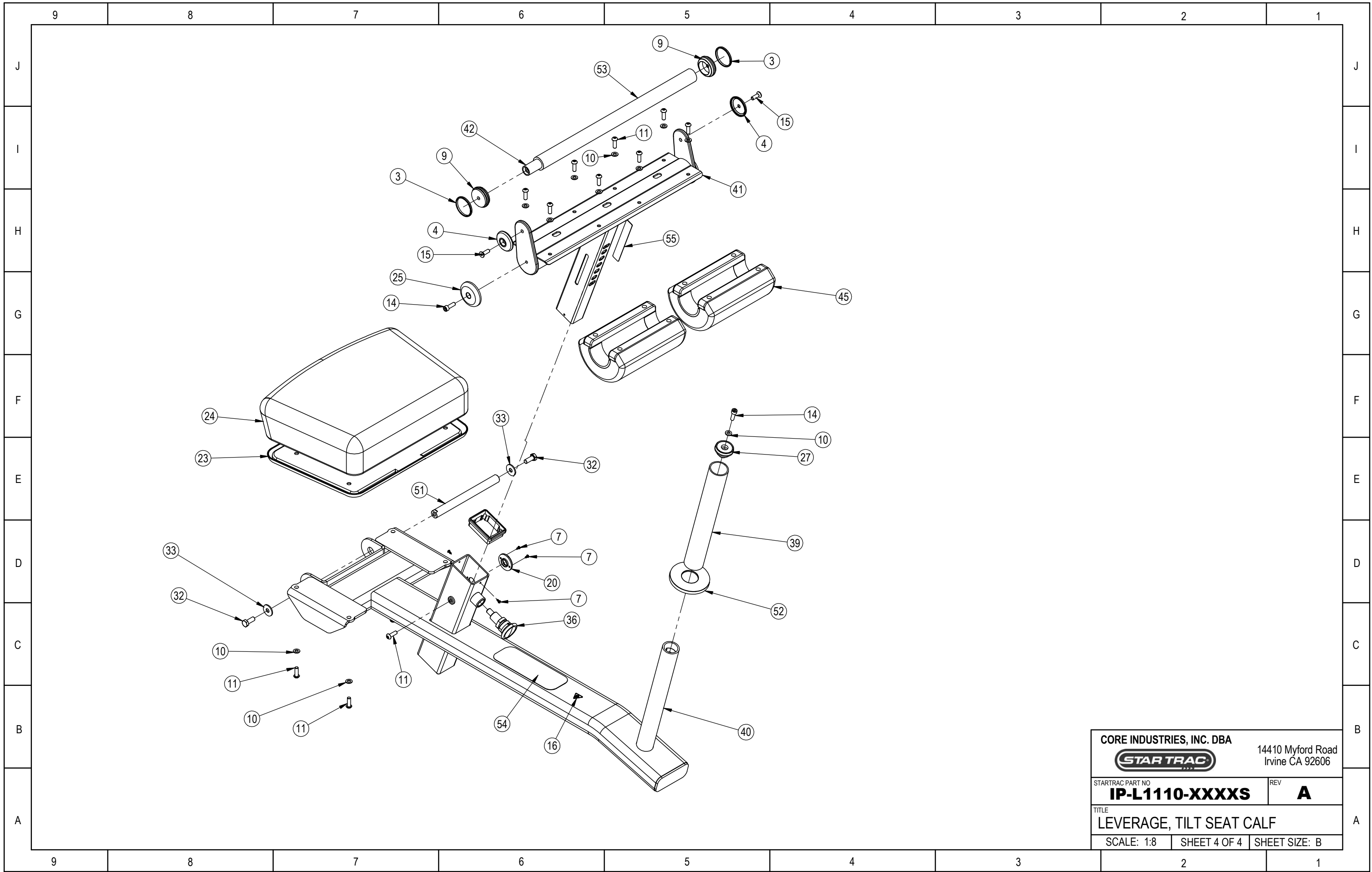

CORE INDUSTRIES, INC. DBA		14410 Myford Road Irvine CA 92606	
<b>STAR TRAC</b>			
STARTRAC PART NO	<b>IP-L1110-XXXXS</b>		REV <b>A</b>
TITLE <b>LEVERAGE, TILT SEAT CALF</b>			
SCALE: 1:8	SHEET 4 OF 4	SHEET SIZE: B	